

These switches are manually operated devices adaptable to a wide variety of applications in pneumatic control systems. They are normally used to perform diverting or supply and exhaust functions to operate final control components or index relays in multiple switching systems.

The 2392-504 is a four-branch switch. The 2392-505 is a five-branch switch that provides one blocked port in each knob position.

The 2393-504 is a four-branch switch which can be used to supply a signal to any one of three devices or supply any one of three signals to a device. Its unused ports are blocked. The 2393-505 is identical except for its unused ports being exhausted to atmosphere.

The 2394-504 and 2394-505 are five-branch switches which follow the same operating pattern as the 2392 series. However, they can supply a signal to any one of four devices or vice-versa. Unused ports are blocked in the 2394-504 and exhausted in the 2394-505.

Various dials are available for each model and for specific switch applications.

Table-1 Ordering Data.

TAC Uni-Line Number	Replaces Model	Description
2392-504	S520	2-Position - 4 branch
2392-505	S521	2-Position - 5 branch (unused ports blocked)
2393-504	S530	3-Position - 4 branch (unused ports blocked)
2393-505	S531	3-Position - 4 branch (unused ports exhausted)
2394-504	S540	4-Position - 5 branch (unused ports blocked)
2394-505	S541	4-Position - 5 branch (unused ports exhausted)

For Dial Plate Ordering Data, see page 2.

Table-2 Mounting Brackets.

TAC Uni-Line Number	Replaces Model	Description
22-155	K511	Single switch bracket
22-156	K512	One switch & one gauge per bracket
22-157	K514	Two switches & two gauges per bracket

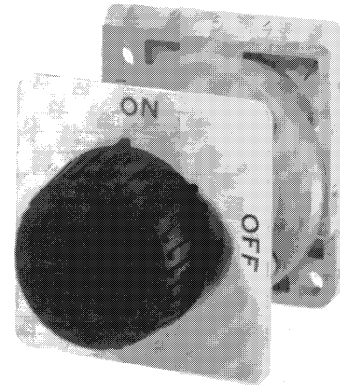

Table-3 Replacement Parts.

TAC Uni-Line Number	Replaces Model	Description
22-173	K550	Replacement knob
22-174	K551	Replacement Locknut

SPECIFICATIONS

Main Air Pressure: 30 psig maximum.

Air Capacity: 40 scfh

Air Consumption: None

Maximum Ambient Temperature: 140°F

Mounting: Designed for use on 22-120 TAC Pneumodular manifold socket. These devices can also be mounted by using the appropriate mounting bracket (see Mounting Bracket ordering data).

Connections: Barbed nipples for 1/4" OD polyethylene or 5/32" ID polyurethane tubing.

Material:

Case, Glass-filled nylon

Dial Plates, Anodized aluminum.

Knob, Black sunburst plastic with pointer.

GENERAL INSTRUCTIONS

These devices are to be used on clean, dry, oil free control air only, and will operate properly when mounted in any position.

The inherent reliability of these devices is enhanced and prolonged through regular inspection and preventive maintenance by a qualified control expert. Should any of these devices become inoperative, it should be replaced by a new unit.

Caution: This device should be installed by a qualified service technician with due regard for safety, as improper installation could result in a hazardous condition.

Table-4 Dial Plate Ordering Data.

TAC Uni-Line Number	Replaces Model	Dial Markings			
2392 SERIES					
22-306	50-06	Blank			
22-309	50-09	Occup.	Unoccup.	—	—
22-311	50-11	Min.	Max.	—	—
22-313	50-13	Winter	Summer	—	—
22-314	50-14	Manual	Auto	—	—
22-315	50-15	Auto	Off	—	—
22-316	50-16	On	Auto	—	—
22-317	50-17	On	Off	—	—
22-318	50-18	Closed	Auto	—	—
22-319	50-19	Open	Auto	—	—
22-320	50-20	Open	Closed	—	—
22-323	50-23	Day	Night	—	—
22-324	50-24	Heat	Cool	—	—
22-352	50-52	1	2	—	—
2393 SERIES					
22-306	50-06	Blank			
22-332	50-32	1	2	3	—
22-237	50-37	Open	Auto	Closed	—
22-338	50-38	Heat	Auto	Cool	—
22-339	50-39	Day	Auto	Night	—
22-345	50-45	Winter	Auto	Summer	—
22-346	50-46	Occup.	Auto	Unoccup.	—
22-347	50-47	On	Auto	Off	—
2394 SERIES					
22-306	50-06	Blank			
22-348	50-48	2	3	4	1
22-349	50-49	Heat	Vent	Cool	Auto

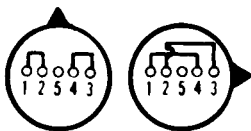

2392-504

PORT 5 BLOCKED

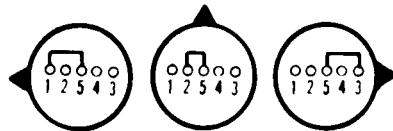

2393-504

PORTS NOT CONNECTED TO 5 BLOCKED

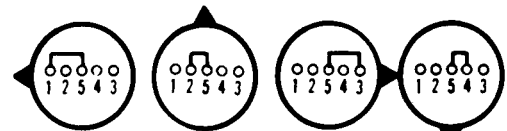

2394-504

PORTS NOT CONNECTED TO 5 BLOCKED

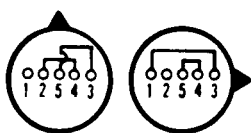

2392-505

PORT 1 BLOCKED PORT 2 BLOCKED

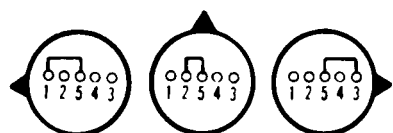

2393-505

PORTS NOT CONNECTED TO 5 VENTED

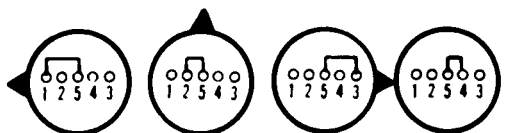

2394-505

PORTS NOT CONNECTED TO 5 VENTED

MOUNTING INSTRUCTIONS

Panel Mounting

Inside: These devices have been designed to be mounted on a Pneumodular manifold socket. One socket, one gasket and two mounting screws are required in addition to the appropriate manifold backplate. Refer to the TAC Pneumodular Parts and Accessories Data Sheet for complete ordering information.

Surface: These devices may also be mounted on a panel face (1/2" maximum panel thickness) by using a 1-1/64" mounting hole. (See Figure-1).

Field Mounting

These devices may also be mounted without the backplate, socket or gasket to replace competitive and old Robertshaw devices by using the appropriate mounting bracket as shown in the ordering information chart on page 1.

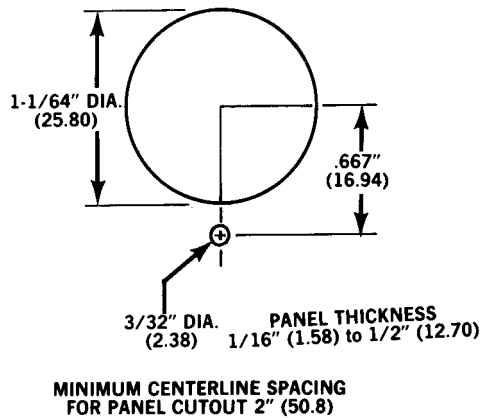

Figure-1

REPLACEMENT OF OLD DEVICES

To replace older models of Robertshaw selector switches (such as factory models S20, S21, S30, S40 or S41) with a -11 designation (example: S20-11), a 22-172 adaptor washer must be used (see Figure-2).

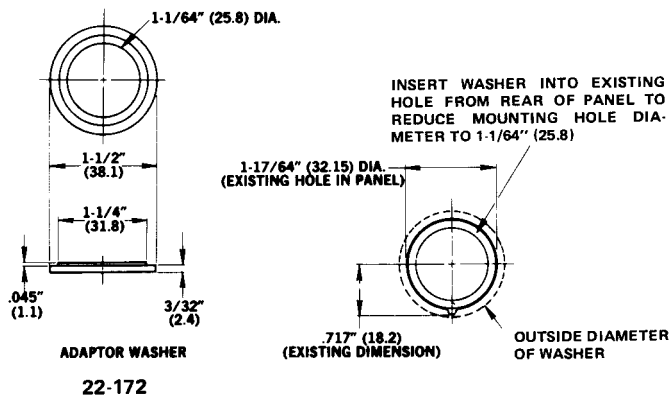

Figure-2

DIAL PLATE INSTALLATION

With the knob removed and the locknut run back for clearance, turn the dial plate to fit over the projections on the front of the switch body. Align and engage the vertical notch in the dial plate with the tab behind the top switch body projection. Tighten the locknut against the back of the dial and replace knob. (See Figure-3).

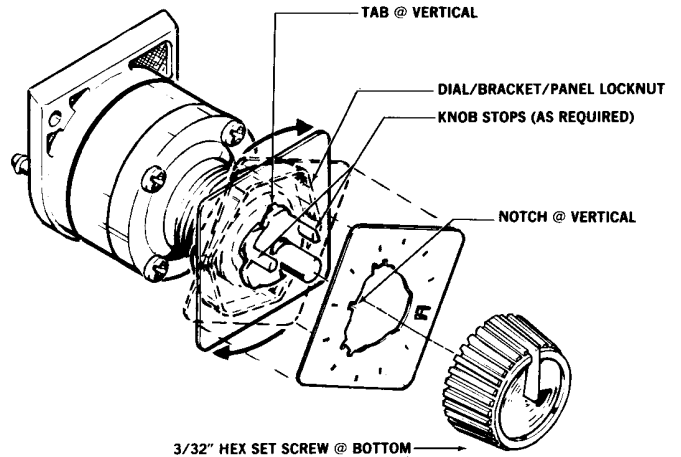

Figure-3

TYPICAL APPLICATION

Automatic or Manual Changeover of Day/Night System

In position 1, the switch will connect ports 1 and 5 supplying 16 psig main air pressure to the thermostat for day operation.

In position 2, the switch will connect ports 2 and 5 supplying either 16 psig main air pressure for day operation, or 25 psig main air pressure for night operation, to the thermostat from an E-P relay being controlled by a programmed timer.

In position 3, the switch will connect ports 3 and 5 supplying 25 psig main air pressure to the thermostat for night operation.

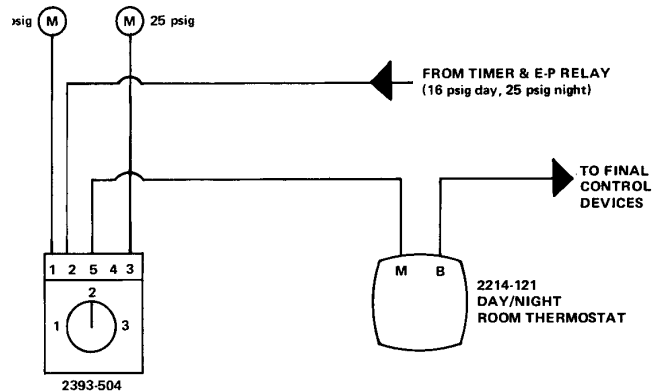
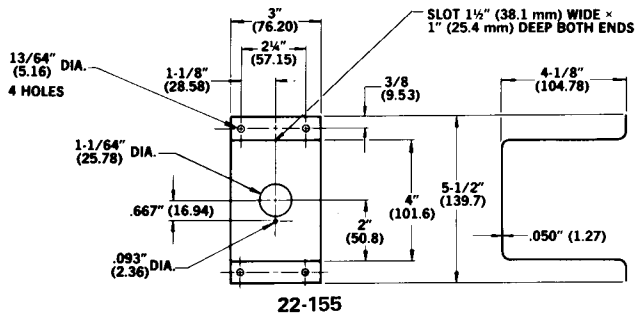
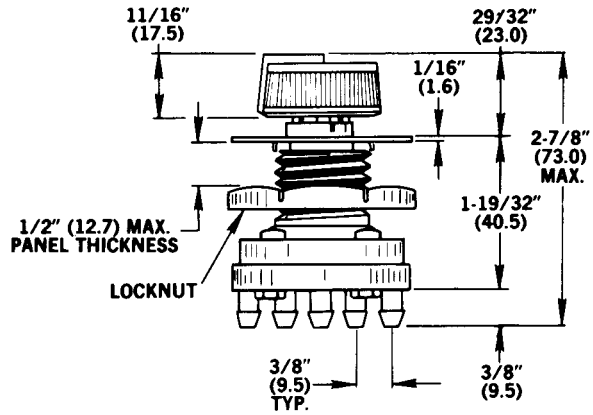
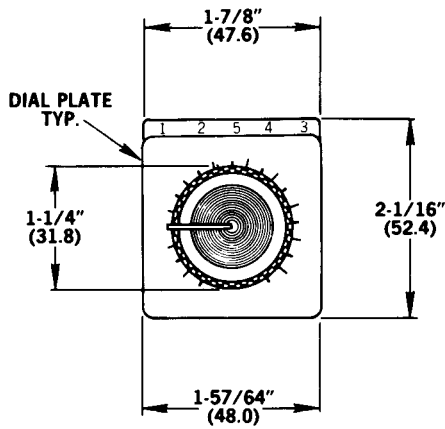
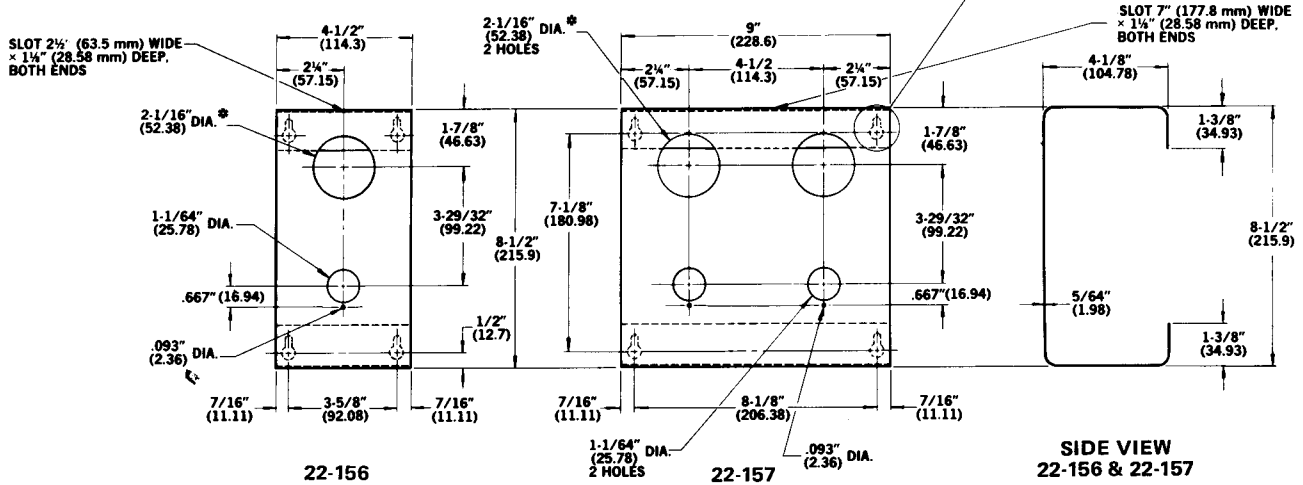
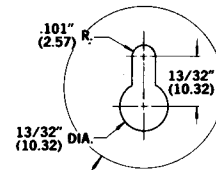

Figure-4

MOUNTING DIMENSIONS



* CUTOUT FOR 2" (50.8 mm) FLUSH U-CLAMP MOUNTED GAGE.



Copyright 2008, TAC
 All brand names, trademarks and registered trademarks are the property of their respective owners. Information contained within this document is subject to change without notice.

TAC
 1354 Clifford Avenue
 P.O. Box 2940
 Loves Park, IL 61132-2940
 www.tac.com

F-24573-2

t.a.c.
 by Schneider Electric